

- **Using TRIZ to a quality improvement**
- **Case study of Foxbro in Shanghai**

GUO Yan; SUN Ming-Gui; XU Ming
Donghua University, Shanghai, P.R.China

Keywords

TRIZ, Quality improvement, Case Study

Abstract

This paper traces the origins of the TRIZ (the theory of inventive solving) from the field engineer technique to management, by exploring not just the benefits associated with TRIZ knowledge and the challenges associated with its acquisition and application based on practical experience. Identifying and appropriately resolving quality improvement problems or effectively evaluating alternatives is a key point. The benefits of applying TRIZ tool to Quality improvements are examined, which it terms contradictions or conflicts. TRIZ recognizes that a novel problem has been integrated to help identify the systems and sub-systems level quality management system for quality improvement. This paper presents using TRIZ to analyze that is useful to identify conflicts of the process of quality improvement in Foxboro, which is necessary to eliminating or reducing the effects factors of the conflicts. Finally, we find that TRIZ has a positive impact on quality improvement process and the potential contribution of quality improvement, while the shortcomings of TRIZ in quality improvement process are discussed. A case study on quality improvement demonstrates the feasibility of applying TRIZ in quality management.

1. Introduction

This paper presents a TRIZ Quality improvement Study Framework, and leverages classic TRIZ tools. And this research shows that with appropriate modification, TRIZ tools can be applied to resolve problems found in operations and quality management system to improve product quality. In the following section, an empirical case study is provided to verify the viability of using TRIZ to solve quality improvement problems. A study was conducted on the improving quality of product in Foxboro. Several TRIZ tools, such as the problem formulator, root contradiction analysis and the 40 inventive principles, were applied with certain modifications. These were used to generate conceptual solutions to address the identified problems in the operation of the quality management system.

2. TRIZ

2.1 Literature Review

The theory of inventive problem solving TRIZ (abbreviation derived from the Russian (Теория решения изобретательских задач)) was developed to provide access for natural scientists and engineers to the knowledge of former inventors. TRIZ originated from former Soviet Union was developed by Genrich Altshuller and his colleagues between 1946 and 1985, which can be also called theory of inventive problems solving in English. and then Boris Zlotin and Alla Zusman founded a technical school to studying on TRIZ in Kishinev, at the same time, Achieve a computerized method represents TRIZ. In 1992, due to the Ideation Company want to adjust and develop TRIZ applied to make the engineering research in United States, so called Ideation period. It is widely used in the European union in 1997 and has speed into Japan, later South Korea, Bulgaria, India, almost 36 countries (Zhang, J. and Shang, J. 2010), which mainly used in engineering, technology and design fields at the beginning of application. In recent years, especially since the establishment of the TRIZ Journal in 1996, there has been greater interest in applying TRIZ to various fields, and then scholars has developed and has been

applied to non-engineering field, such as business, social study, quality management, education, service operations management, finance, marketing, architecture (Zlotin Boris, Zusman Alla. 2001, Terninko John 2001, Retseptor Gennady. 2003, Marsh Dana G., Waters Faith H., Marsh Tabor D. 2004, Zhang Jun, Hai Kah-Hin, Tan Kay-Chuan 2003, Dourson Stephen. 2003, 2004, Retseptor Gennady. 2005, Mann Darrell L. 1999, 2001, 2004, Bowyer 2008), in according to study on applications with 40 Inventive Principles with interpretation in commercial areas. Savransky (2000) argued when we have known a little (unknown causes and unknown search directions), that only TRIZ would be useful for solving difficult problems, which many Fortune 500 companies have successfully applying TRIZ for increasing in productivity with the breakthrough ideas and quality solutions to problems. Bruno Ruchti (2001), summarized from 40 TRIZ principles and summed up in the 12 principles of TRIZ innovation management and procedures in solving conflict and improve produce quality management. Blackburn, Mazzuchi, and Sarkani (2011) related to some case on an emerging approach to pharmaceutical development and manufacturing; The integration of TRIZ with other methodologies, such as quality function deployment (Domb, 1998; Schlueter, 2001; Terninko, 1998) and six sigma (Tennant, 2003; Verduyn, 2002); Prakasan Kappoth, Kushagra Mittala, (2008) in business strategic, to solve complex management of conflict in TRIZ, and doing a case study. Aziguli (2004) TRIZ is not only can solve the contradiction between the physical and technical engineering problems can also be used for non-engineering fields, particularly for solving management problems such as resource management conflicts, cost and quality contradictions.

2.2 The concept of TRIZ

TRIZ consists of the following concepts. a) System. The research object be consisted of any system includes one or more subsystems each perform their functions, it can be divided into smaller subsystems. When solving system problems, and often have to consider the interaction between subsystems and the upper system, all subsystems are connected to each other at a higher level system, a subsystem change will inevitably affect the entire system, Idealized means a system or subsystem optimal use of existing resources. b) Conflict. Based on TRIZ, the system conflict was divided into three ways: First, when change a particular feature or parameters to improve the system, will produce incompatibilities between parameters or characteristics, that "technical conflict." Based on traditional methods to solve the technical problem is the conflict between multiple criteria seek "compromise", each parameter cannot achieve the best value. The TRIZ is to seek a breakthrough way to eliminate conflict in order to attain optimal (Pareto improvement), is also called "no compromise design"; second is the "physical conflict" refers to the system with state conflict or contrary requirements. Physical conflict means realize a function to a subsystem or component should have a property, but there has been a characteristic opposite to the characteristic; third, Genrich Altshuller defined conflict management refers to certain phenomena or wish to avoid some of the results obtained, the need to do something, but he do not know how to do it. But he believes the temporary management of the conflict itself, without enlightening. c) System evolution. Evolution of the system is divided into four stages: infancy, growth, maturity and decline, and to determine the evolution of the characteristics and laws of each stage, innovative problem solving for the designer to provide guidance. Any system is moving in the direction of an idealized, that is, toward more reliable, simple and effective direction.

The so-called conflict management refers to the state between incompatible systems capabilities in managed objects that appear in the system and the system objectives to be achieved. Here, the system has the ability to target the multilevel nature of the system. Manage conflict situations arise: (1) the existence of a lack of capacity among businesses and the objectives to be achieved; (2) to achieve business goals has been limited in the external

environment; (3) to reach a goal of harm to another subsystem, or reach multiple subsystems, or systems objectives; (4) the cognitive conflict and emotional conflict on the system or subsystem goal achievement damage.

2.3 The TRIZ methodology

TRIZ theory has research methods and tools as following. See table 1.

Table 1 Research tools and methods

Tools and methods	Principles and functions
40 inventive principles Management System	The key is solving technical contradictions, these principles reflects the innovative awareness and conflict management processes.
39 Technical characteristics and conflict matrix	In the process of solving the problem of the system, when a technique to improve the characteristics of the system, often worsen other technical features make the system, which will produce a technical violation. Conflict matrix system to solve the conflict created by the conflict relationship expressed in matrix form.
Substance Field Analysis	It is symbolic expression technology system transformation modelling techniques. "Substance" in the meaning of the expression in triz very broad, can range from simple objects to having various levels of complexity. Field "is used to express the interaction between two objects, the energy necessary for the control.
Algorithm for Inventive problem solving (ARIZ)	ARIZ is to provide simplistic solutions for complex problems logically structured process, Which is TRIZ analysis of the problem, is the main tool for solving problems. The key is in order to get success lies in the application ARIZ did not understand the nature of the problem in advanced, we must continue to refine the issues have been identified to physical conflict. The process and the physical conflict solving existing software support.

This is a famous principle called 40 inventive principles management system. they are division, removing, partially changed, feedback, asymmetry, combination, multi-faceted, nested structure, counterweight, prior reaction, the pre-operation, prevention, prevention countermeasures in advance, eliminate tension, inverse problem, surface of recovery, dynamics, slight, changes in dimensions ,vibration. Swing, cyclical behavior, sustained behavior, acceleration, changed for the benefit of victims, feedback, intermediary, self-service, copy, use cheap, different senses, liquidity, tiny and flexible, hole, color change, homogeneity, rehabilitation, parameters, state transitions, relative change, rich and concentrated, calm, composite synthetic.

2.4 Project of the study-Improvements in product innovation

Flowchart can be used to describe the TRIZ tools and methods. The figure 1 not only describes the relationship between the various tools, but also describes the product innovation and quality improvement issues. The first step in the application of TRIZ is to analyze a given problem; If you find there is a conflict, then the application of the principle to solve; If the problem is clear, but do not know how to solve, apply effects to solve; third option is to treat innovation technology systems to predict the evolutionary process. After evaluating we achieved

ideal solution. This process can be used to achieve the traditional manual method, may also help to achieve computer software.

Among firstly, Analysis includes defining the problem, functional analysis, to determine the ideal solution, available resources and conflict analysis to determine etc. If the problem has been found in the analysis phase of the solution, you can move to the implementation phase; If we do not find the solution to the problem, and the solution of the problem need to maximize innovation, knowledge-based three tools: principle, and so can be used to predict and effect .Secondly Application of principles , using TRIZ to guide the selection principle problem solvers can solve specific conflicts, the premise is to determine the conflict according to the standard parameters. Thirdly, in its current stage of evolution and evolutionary patterns, predict trends, and then design the system design, systems, subsystems and components should be in the direction of high-level development based on trends in the evolving process of solving design problems. Fourthly, Effect refers to the application of the field, particularly in relation to other areas of the law to solve design problems. At last, improved solution and compares the ideal solution, made sure that stage would have obtained not only solved both problems and meet the needs, and promote innovation. If you still cannot meet the needs of an ideal solution, the system can be re-analyze the problem, determine the conflict matrix, solve new problems, and loop until a satisfactory solution so far.

3. Case study- The research approach taken

3.1 Introduction Foxbro in shanghai

Foxboro American Company was founded in 1908, until 1985 it had become in a variety of models and different levels of complexity of pneumatic and electronic manipulation of the instrument and computer control systems leading global suppliers. In 1984 the company's sales more than 500 million U.S. dollars, the production process in the world has the largest market share of control equipment. Shanghai Foxboro Co., Ltd. was established on April 13, 1983. Shanghai Electronics Development Holding (Group) owns all the shares to transfer all Invensys in April 2011, so far, Shanghai Foxboro Co., Ltd. on the joint enterprise into the Invensys Group, a wholly owned enterprise. Invensys is a global technology company that works in partnership with a broad range of industrial and commercial customers to design and supply advanced technologies that optimize their operational performance and profitability. From oil refineries and power stations to mining companies and appliance manufacturers, our market-leading software, systems and controls enable our customers to monitor, control and automate their products and processes, thereby maximizing safety, efficiency, reliability and ease of use. Active in over 180 countries, we employ more than 16,500 people across four business segments: Software, Industrial Automation, Energy Controls and Appliance. Shanghai Foxboro Co., Ltd. is China's leading industrial automation instrumentation and control system manufacturer. Customers across various industrial fields of petroleum, chemical, natural gas, cement, paper, textile, food, medicine, mining, metals, power, water and wastewater treatment and laboratories. Products throughout the country all provinces except Tibet and sold back to the United States, Germany, Italy, Australia, India, Singapore, Japan, Korea, Malaysia and other countries. Invensys is changing business development approach, to promote market-leading quality and reliability. We want to provide customers with process automation and control solutions to meet all of the processing industry enterprises (from independent processes basic, reliable functionality to control critical or hazardous operation of complex integrated enterprise) needs. Learning solutions are designed to be achieved by maximizing plant availability and utilization:

- ensure consistency of approach and application
- By reducing the wrong way, applications and designed to manage risk

- Improve maximize revenue and profits through performance

3.2 Application TRIZ tools in Foxbro in shanghai

Enhancing customers' productivity is the most important thing in Foxboro in shanghai. Advanced technologies are used by customers in plants and facilities around the world, helping to give them a competitive edge by speeding up their processes, improving accuracy, saving time, cutting waste and boosting their safety and sustainability performances. Long-term sustainable growth is driven by an absolute commitment to project and commercial execution excellence, which also drives continually improvement quality.

The methodology for this research is based on a preliminary investigation of TRIZ tools in Eco-innovation case study of domestic dishwashing (Elies Jones, Darrell Mann, David Harrison and Neville A. Stanton 2001), the study show that the whole thought about and helped how to do through using the TRIZ tools used. To capture the situation questionnaire were selected and modified (see Jun Zhang, kah-Hin Chai & Kay-Chuan Tan, 2005), all of which have to be addressed during the process of solving a problem and thus during the process of inventing:

- Current state: What does the current situation look like?
- Analysis problem: what might be the possible solution to improvement quality problems? Which resources are available? What might the advantaged and disadvantages of these solutions?
- Goals: Which goals shall be fulfilled? What might be the ideal solution to address the improvement quality problem?
- Intended state: How is the future situation supposed to look like?
- Transformation: In which way can the current state be transferred into the intended state?

3.3 Improvement quality model to determine

Through an investigation of the quality management manager and operations staff, information was obtained, structured and processed using TRIZ's tools and countering methods. The general idea is that, the application of 40 management principles in the general problem management process, we can get the general solution and specific to a specific program can get a particular solution, and then the relevant parameters and application management issues specific management problems last become into general management issues.

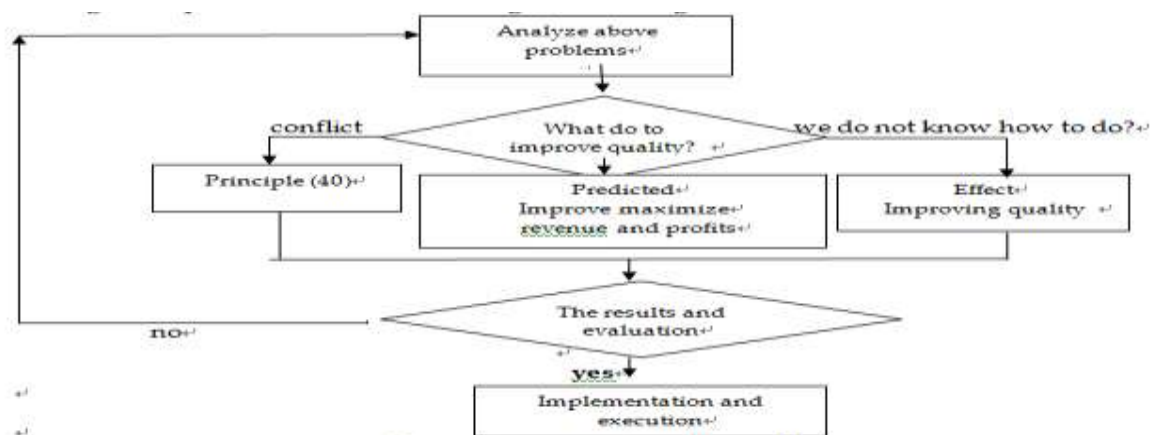

Figure 1 improvement quality models

Figure 1 improvement quality models

3.4 Analyses and results

Current state: Foxboro I/A'S System in Shanghai refinery distillation unit, among Optimize I/ A'S temperature protection system logic, But in the actual production process, due to the

occurrence of temperature measurement devices or terminal wiring bad break loose, causing the measured temperature suddenly rose, auxiliary temperature protection action nuisance tripping, seriously affecting the stable operation of the unit.

Analyze and define problems: Thermal resistance varies with temperature is the principle of using made of a metal conductor resistance, heat resistance when the terminal disconnection and poor contact, the contact resistance will increase, it is for the protection of its temperature rises suddenly occurred protection action; while thermal control personnel at work, the demolition will occur resulting in disconnection wrong temperature measurement devices as possible, which also led to a temperature protection action. After analysis, the following may be several reasons disoperation:

- . Auxiliary long-running, long-term vibration caused by loose terminals;
- . Thermal resistance factors causing equipment damage, disconnection;
- . Thermal Engineering staff mistakenly removed overhaul components, resulting in thermal resistance break;
- . Thermal resistance is itself quality defects, internal disconnection and failure.

The original auxiliary temperature protection logic used in the following figure 2:

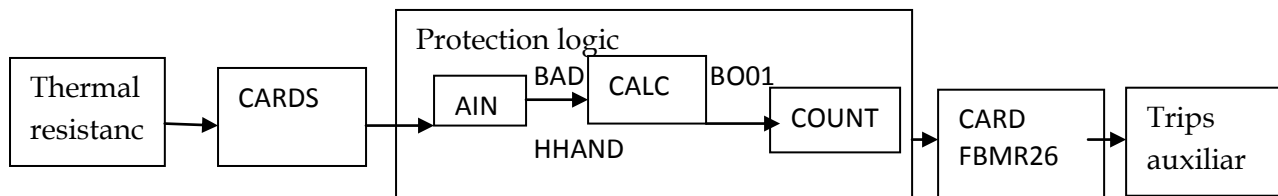

Figure 2 Protection logic

Here joined the bad quality of judgment, but the actual effect is not obvious. Practice has proved that the temperature of elements present in the disconnection delay, not immediately on the bad, the other terminal is bad, its resistance suddenly large and small, which may exist to protect the malfunction. It seems that simply relying on bad value judgment does not solve the problem, but also the rate of change of the temperature value judgments, so as to avoid the protection of malfunction.

Goals and Intended state: Focus question becomes how to decision of perform the rate, we want to start at the same temperature by comparing the phase difference between the front and rear to get the rate, then by finding the I / A system data, we find REALM module, it can achieve the change Analyzing rate, when the rate exceeds the set value, an instruction signal sent Boolean. This provides the conditions for logic and lockout protection output. IFR ideal solution is to meet the final does not change the original assembly methods, without the harmful consequences of the introduction of new requirements, eliminate excessive and deep catalog of harmful factors, ensuring easy assembly and release can be submitted. Managing conflicts are required to maintain the original version of the original structure to ensure that the assembly function point mode, in order to simplify the code directory organizations version submitted.

Improve and Transformation: firstly, on the protection switching. Removal of the protection when needed, will be set 0 to BI06 of CALC block, BO01 limit its output; necessary inputs, without the protection checking is abnormal, is set 1 to BI06 a CALC block. Secondly, alarm screen. After the temperature element anomaly, an alarm output by the BO02 CALC block via the alarm logic, in a group picture sent alarm sound and light alarm, prompting operators to contact thermal control for processing. Thirdly, speed limits value. Alarm rate fixed value of 3 °C / s. After modifying the protection logic is as follows figure 3: As a result, Increase the temperature alarm rate limiting and temperature element anomalies later.

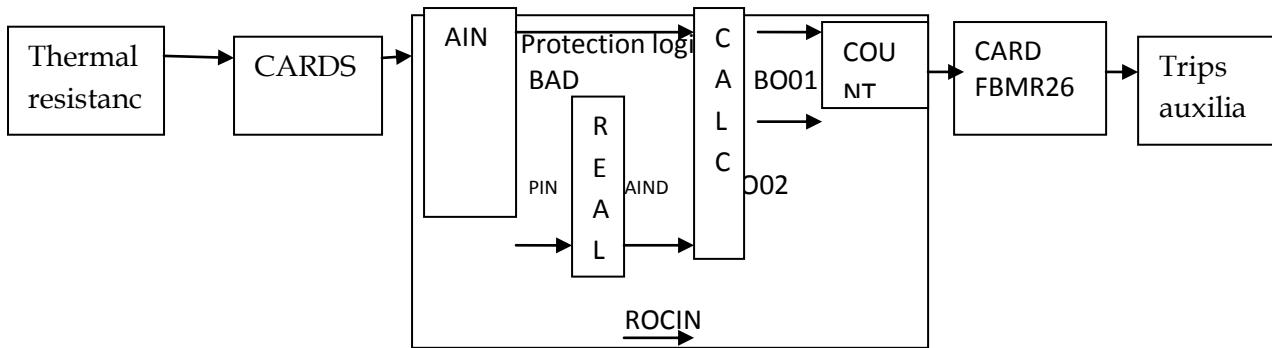

Figure 3 Modifying Protection logic

Evaluate. By testing proved that the method is effective and feasible, and without any additional equipment, to achieve the desired functionality. We have it for blower, fan, mill, a fan of mill, electric feed pump, condensation on temperature protection pumps, circulating pumps and other important auxiliaries, has successfully avoided twice due to thermal resistance abnormalities caused by malfunction. This logic can also be used to protect the thermocouple temperature measurement; the rate limiting function REALM module greatly improves the logical configuration of convenience. To sum up, they hope to get the majority of the use of I / A system unit from inspiration, with live, with a good control system.

4. Conclusions

4.1 Conclusion

In this paper, the general TRIZ problem solving process made some improvements expansion presents a process model for solving the conflict TRIZ -based management , that is a " defined - Conversion - solving tools approach - based on the predicted improvements - Evaluation and Control" closed loop. At the same time , gives the analytical tools and methods need to be applied at each stage of the program management dimension TRIZ , and can be integrated using the management process optimization tools, and can be applied to other aspects of general application in the field of business management.

Firstly, TRIZ has identified that systems inherently ultimately evolve in a direction of increasing, ideality, a part of which says that the 'harm' in a system will decrease. The case study here has demonstrated how TRIZ could be applied to improve quality. Secondly, looking at the solutions generated in relation to the original problem hierarchy diagram reveals that both the trends and the contradiction matrix generated patentable solutions at the sub-systems level. Thirdly, some questions should be answered by theoretical researchers. it seems to be useful to evaluate which other tools like synaptic or semantic patent analysis should be applied together with TRIZ tools. All in all, some explorative answers to the research questions have been given in this paper. These answers can be the foundation for testable hypotheses, which should be investigated in further empirical research.

4.2 Limitations and future research

As with any research, there are limitations associated with the studies. Therefore, the design of this study is subject to limitations that open up opportunities for future research. With a powerful knowledge base as its foundation, as a new area in which to apply TRIZ methodologies, is receiving increasing attention. Taking this as an objective, this research project applied modification of selected TRIZ tools, such as the problem formulator and the 40 inventive principles, to resolve problems in service operations. Its successful application in this case study the premise that the TRIZ knowledge base is applicable to a wide scope of problem solving situations. In the present case study, the use of TRIZ tools redefined the problem

situation, revealed the inherent contradiction and generated multiple quality solutions. Moreover, during the problem-solving process, ideas were generated throughout the entire conceptual design process. In this paper, the case study pointed out that although TRIZ -dimensional analysis tools and methods can set methods in the field of improving quality. But there is no way to manage the relationship analysis of TRIZ -dimensional pure management between management theory and how to mix between them, which are the focus of future research.

Reference

- Altshuller, G.S. (1984) *Creativity as an Exact Science: The Theory of the Solution Inventive Problems*. Gordon & Breach Science Publishing, New York.
- Altshuller, G.S. (1997), *40 Principles: TRIZ keys to technical innovation*, trans. and ed. Shulyak, L., Rodman, S. *Technical Innovation Center*, Worcester,
- Bowyer, D. (2008), "Evaluation of the effectiveness of TRIZ concepts in non technical problem solving: utilizing a problem solving guide", *PhD thesis, Pepperdine University*, Malibu.
- Bruhl, R., Horch, N. and Osann, M. (2010), "Improving integration capabilities with management control", *European Journal of Innovation Management*, 13 (4), 385-408.
- Bowers, M.R. (1989) *Developing new services: Improving the process makes it better*. *The Journal of Service Marketing*, 3(1), 15-20.
- Congram, C. and Epelman, M. (1995) *How to describe your service: An invitation to the structured analysis and design technique*. *International Journal of Service Industry Management*, 6(2), 6-23.
- Duran-Novoa, R., Leon, N., Aguayo, H. and Said, D. (2011), "Inventive problem solving based on dialectical negation, using evolutionary algorithms and TRIZ heuristics", *Journal of Computers in Industry*, 62, 437-445.
- Eversheim, W. (2009), *Innovation Management for Technical Products: Systematic and Integrated Product Development and Production Planning*. Springer-Verlag, Berlin Heidelberg.
- Ericson, A., Bertoni, M. and Larsson, T. (2009), "Needs and requirements - how TRIZ may be applied in product-service development", paper presented at Second Nordic Conference on Product Lifecycle Management - NordPLM'09, Goteborg, January 28-29.
- Elies Jones, Darrell Mann, David Harrison and Neville A. Stanton (200), *Eco-innovation case study of domestic dishwashing through the application of TRIZ tools, creativity and innovation management*, *Blackwell publishers* 10(3), 3-14
- Fresner, J., Janstchgi, J., Birkel, S., Barntharel, J. and Krenn, Ch. (2010), "The theory of inventive problem solving (TRIZ) as option generation tool within cleaner production projects", *Journal of Cleaner Production*, 18 (2), 128-136.
- Gadd, K. (2011), *TRIZ for Engineers: Enabling Inventive Problem Solving*, Wiley, London.
- Hipple, J. (2005), "40 inventive principles with examples for chemical engineering", *TRIZ Journal*, June, available at: <http://www.triz-journal.com/archives/2005/06/06.pdf>
- Jun Zhang, Kah-Hin Chai & Kay-Chuan Tan (2005), *applying TRIZ to Service Conceptual Design: an exploratory study, creativity and innovation management*, *Blackwell publishers*, 14, 3, 34-42
- Kim, J., Kim, J., Lee, Y., Lim, W. and Moon, I.I. (2009), "Application of TRIZ creativity intensification approach to chemical process safety", *Journal of Loss Prevention in the Process Industries*, 22(6), 1039-1043.
- Kelly, D. and Storey, C. (2000). *New service development: initiation strategies*. *International Journal of Service Industry Management*, 11(1), 45-62.

-
- Low, M.K., Trond L., Kathryn W. and Odd, M. (2001) Manufacturing a green service: Engaging the TRIZ model of innovation. *IEEE Transactions on Electronic Packaging Manufacturing*, 24(1).
- Li, T. (2010), "Applying TRIZ and AHP to develop innovative design for automated assembly systems", *International Journal of Advanced Manufacturing Technology*, 46 ,1-4,301-313.
- Mann, D. and Domb, E. (2001) Using TRIZ to Overcome Business Contradictions: Profitable E-Commerce. *TRIZ Journal*, April.
- Marsh, D., Waters, F. and Mann, D. (2002) Using TRIZ to Resolve Educational Delivery Conflicts Inherent to Expelled Students in Pennsylvania. *TRIZ Journal*, November.
- San, Y.T., Jin, Y.T. and Li, S.C. (2009), Theory of Inventive Problem Solving TRIZ, Systematic Innovation in Manufacturing, *Firstfruits Sdn. Bhd., Petaling Jaya*.
- Sreebalaji, V.S. and Saravanan, R. (2009), "Advanced electrical discharge machining and TRIZ", *TRIZ Journal*, June, available at: <http://www.triz-journal.com/archives/2009/06/02>
- Terninko, J. (2001), "40 inventive principles with social examples", *TRIZ Journal*, June, available at: <http://www.triz-journal.com/archives/2001/06/a/index.htm>
- Tennant, G. (2003) TRIZ for Six Sigma. Mulbury SixSigma, available at: http://www.sixsigmatriz.com/TRIZ_ebook.htm.
- Zhang, J. and Shang, J. (2010), "Research on developing environmental protection industry based on TRIZ theory", *Procedia Environmental Sciences*, ,2, 1326-1334.
- Zeithaml, V.A. and Bitner, M.J. (2000) Services marketing: integrating customer focus across the firm. Irwin/McGraw Hill, Boston, MA.
- Zhang, J., Chai, K.H. and Tan, K.C. (2003) 40Inventive Principles with Applications in Service Operations Management. *TRIZ Journal*, December.
-